

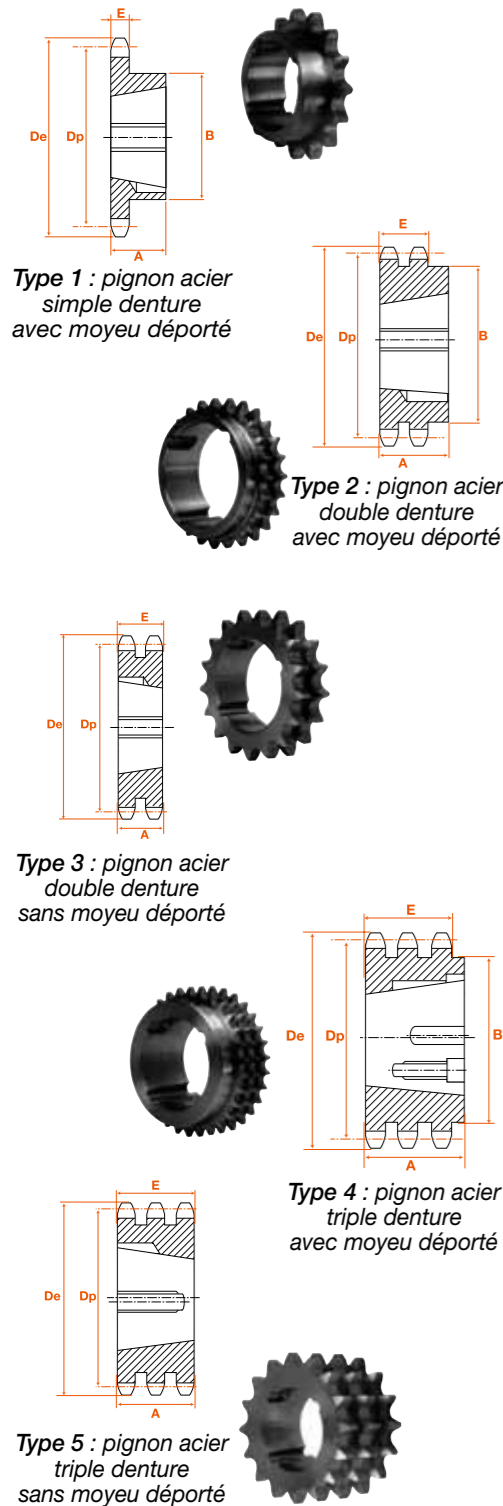

Moyeux amovibles  
présentés section 6

STOCK ET PRIX  
SUR ITAFRAN.COM

**CARACTERISTIQUES DIMENSIONNELLES**



Côte E	
Simple denture	5,3 mm
Double denture	15,4 mm
Triple denture	25,6 mm

06B - 3/8" x 7/32"									
Chaîne largeur intérieure 5,72 - Ø rouleau 6,35									
Dents	Code	De	Dp	Moyeu mini maxi	Type	A	B	Masse	
<b>Simple</b>									
17	PGS09517M	55,3	51,83	1008	10/25	1	22	45	0,10
18	PGS09518M	58,3	54,85	1008	10/25	1	22	45	0,10
19	PGS09519M	61,3	57,87	1008	10/25	1	22	45	0,20
20	PGS09520M	64,3	60,89	1008	10/25	1	22	46	0,20
21	PGS09521M	68,0	63,91	1008	10/25	1	22	46	0,30
22	PGS09522M	71,0	66,93	1008	10/28	1	22	50	0,30
23	PGS09523M	73,5	69,95	1210	11/32	1	25	63	0,30
24	PGS09524M	77,0	72,97	1210	11/32	1	25	63	0,30
25	PGS09525M	80,0	76,02	1210	11/32	1	25	63	0,40
26	PGS09526M	83,0	79,02	1210	11/32	1	25	63	0,40
27	PGS09527M	86,0	82,02	1210	11/32	1	25	63	0,50
28	PGS09528M	89,0	85,07	1210	11/32	1	25	63	0,50
30	PGS09530M	94,7	91,12	1210	11/32	1	25	63	0,60
38	PGS09538M	119,5	115,35	1210	11/32	1	25	70	1,00
45	PGS09545M	140,7	136,55	1210	11/32	1	25	70	1,60
57	PGS09557M	176,9	172,91	1210	11/32	1	25	70	2,00
<b>Double</b>									
17	PGD09517M	55,3	51,83	1008	10/25	2	22	41	0,10
18	PGD09518M	58,3	54,85	1008	10/25	2	22	43	0,10
19	PGD09519M	61,3	57,87	1008	10/25	2	22	46	0,20
20	PGD09520M	64,3	60,89	1008	10/25	2	22	48	0,20
21	PGD09521M	68,0	63,91	1008	10/25	2	22	49	0,30
22	PGD09522M	71,0	66,93	1108	10/28	2	22	52	0,30
23	PGD09523M	73,5	69,95	1210	11/32	2	25	59	0,30
24	PGD09524M	77,0	72,97	1210	11/32	2	25	61	0,30
25	PGD09525M	80,0	76,00	1210	11/32	2	25	64	0,40
26	PGD09526M	83,0	79,02	1210	11/32	2	25	65	0,40
27	PGD09527M	86,0	82,05	1210	11/32	2	25	70	0,50
28	PGD09528M	89,0	85,07	1210	11/32	2	25	70	0,50
30	PGD09530M	94,0	91,12	1210	11/32	2	25	75	0,60
38	PGD09538M	119,5	115,35	1610	14/42	2	25	80	1,00
45	PGD09545M	140,7	135,55	1610	14/42	2	25	80	1,60
57	PGD09557M	176,9	172,91	1610	14/42	2	25	80	2,00
<b>Triple</b>									
17	PGT09517M	55,3	51,83	1008	10/25	5	25,6	-	0,10
19	PGT09519M	61,3	57,87	1008	10/25	5	25,6	-	0,20
21	PGT09521M	68,0	63,91	1008	10/25	5	25,6	-	0,30
23	PGT09523M	73,5	69,95	1210	11/32	5	25,6	-	0,30
25	PGT09525M	80,0	76,00	1210	11/32	5	25,6	-	0,40
27	PGT09527M	86,0	82,05	1210	11/32	5	25,6	-	0,50
30	PGT09530M	94,0	91,12	1615	14/42	4	38	79	0,90
38	PGT09538M	119,5	115,35	1615	14/42	4	38	90	1,80

La forme des pignons et le type de montage des moyeux sont donnés à titre indicatif et peuvent être modifiés sans préavis. En cas de nécessité, notre service commercial vous indiquera les caractéristiques exactes des types de pignons disponibles au moment de votre commande.

Sprockets' shapes and hubs' assembling are given as a guide. They can be modified without any notice. If necessary our sales department can inform you about their exact types we have in stock just as you place your order.

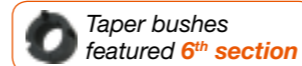

Taper bushes  
featured 6<sup>th</sup> section

STOCK AND PRICES  
ON ITAFRAN.COM

08B - 1/2" x 5/16"									
Chaîne largeur intérieure 7,75 - Ø rouleau 8,51									
Dents	Code	De	Dp	Moyeu mini maxi	Type	A	B	Masse	
<b>Simple</b>									
14	PGS127N14M	61,8	57,07	1008	10/25	1	22	-	
15	PGS127N15M	65,5	61,09	1008	10/25	1	22	45	0,20
16	PGS127N16M	69,5	65,10	1108	10/28	1	22	50	0,20
17	PGS127N17M	73,6	69,11	1210	11/32	1	25	60	0,20
18	PGS127N18M	77,8	73,14	1210	11/32	1	25	60	0,30
19	PGS127N19M	81,7	77,16	1210	11/32	1	25	63	0,30
20	PGS127N20M	85,8	81,19	1610	14/42	1	25	71	0,30
21	PGS127N21M	89,7	85,22	1610	14/42	1	25	71	0,40
22	PGS127N22M	93,8	89,24	1610	14/42	1	25	71	0,40
23	PGS127N23M	98,2	93,27	1610	14/42	1	25	76	0,50
24	PGS127N24M	101,8	97,29	1610	14/42	1	25	76	0,50
25	PGS127N25M	105,8	101,33	1610	14/42	1	25	76	0,60
26	PGS127N26M	110,0	105,36	1610	14/42	1	25	76	0,60
27	PGS127N27M	114,0	109,40	1610	14/42	1	25	76	0,60
28	PGS127N28M	118,0	113,42	2012	14/50	1	32	90	0,70
30	PGS127N30M	126,1	121,50	2012	14/50	1	32	90	0,90
38	PGS127N38M	158,6	153,80	2012	14/50	1	32	90	1,30
45	PGS127N45M	188,0	182,07	2012	14/50	1	32	100	1,70
57	PGS127N57M	236,4	230,54	2012	14/50	1	32	100	3,00
<b>Double</b>									
14	PGD12714M	61,8	57,07	1008	10/25	2	22	46	0,20
15	PGD12715M	65,5	61,09	1008	10/25	2	22	46	0,20
16	PGD12716M	69,5	65,10	1108	10/28	2	22	50	0,20
17	PGD12717M	73,6	69,11	1210	11/32	2	25	56	0,20
18	PGD12718M	77,8	73,14	1210	11/32	2	25	60	0,30
19	PGD12719M	81,7	77,16	1210	11/32	2	25	62	0,40
20	PGD12720M	85,8	81,19	1610	14/42	2	25	66	0,40
21	PGD12721M	89,7	85,22	1610	14/42	2	25	70	0,40
22	PGD12722M	93,8	89,24	1610	14/42	2	25	76	0,50
23	PGD12723M	98,2	93,27	1610	14/42	2	25	79	0,60
24	PGD12724M	101,8	97,29	2012	14/50	2	25	84	0,60
25	PGD12725M	105,8	101,30	2012	14/50	2	32	87	0,90
26	PGD12726M	110,0	105,36	2012	14/50	2	32	87	0,90
27	PGD12727M	114,0	109,40	2012	14/50	2	32	87	0,90
28	PGD12728M	118,0	113,42	2012	14/50	2	32	87	1,00
30	PGD12730M	126,0	121,50	2012	14/50	2	32	87	1,20
38	PGD12738M	158,0	153,80	2012	14/50	2	32	100	2,50
45	PGD12745M	188,0	182,07	2012	14/50	2	32	100	3,70
57	PGD12757M	236,0	230,54	2012	14/50	2	32	100	5,90
<b>Triple</b>									
15	PGT12715M	65,5	61,09	1008	10/25	5	34,9	-	0,30
17	PGT12717M	73,6	69,11	1210	11/32	5	34,9	-	0,40
19	PGT12719M	81,7	77,16	1210	11/32	5	35	-	0,40
21	PGT12721M	89,7	85,22	1610	14/42	5	35	-	0,60
23	PGT12723M	98,2	93,27	1615	14/42	5	35	-	0,90
25	PGT12725M	105,8	101,30	2012	14/50	5	35	-	0,90
27	PGT12727M	114,0	109,40	2012	14/50	5	35	-	1,20
30	PGT12730M	126,1	121,50	2012	14/50	5	35	-	1,90
38	PGT12738M	158,6	153,80	2012	14/50	5	35	-	3,50

**CARACTERISTIQUES DIMENSIONNELLES**

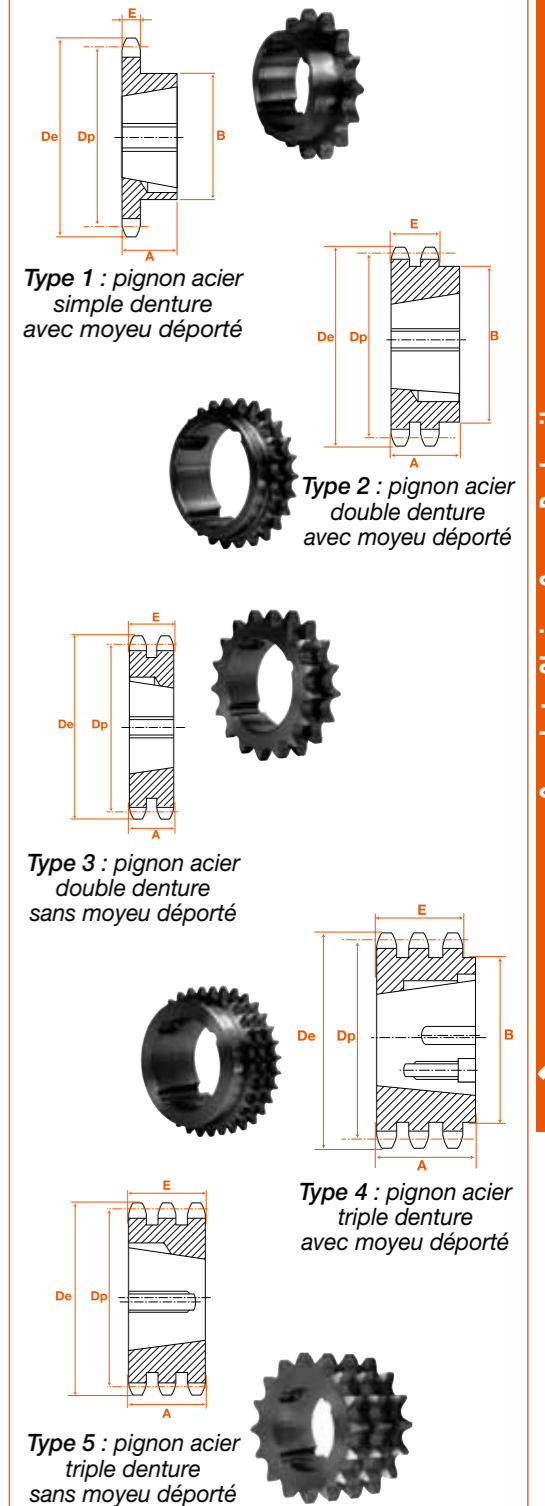

Côte E	
Simple denture	7,2 mm
Double denture	21,0 mm
Triple denture	34,9 mm